

# OUTDOOR PLAY

6. If desired, create an indoor obstacle course. Construct a 4' x 4' x 6' cube from PVC pipe and connectors. Wind the string spider-web style throughout the box. Each child may either crawl through the box without the string touching her, or may unravel the string with coaching from a team of three friends.

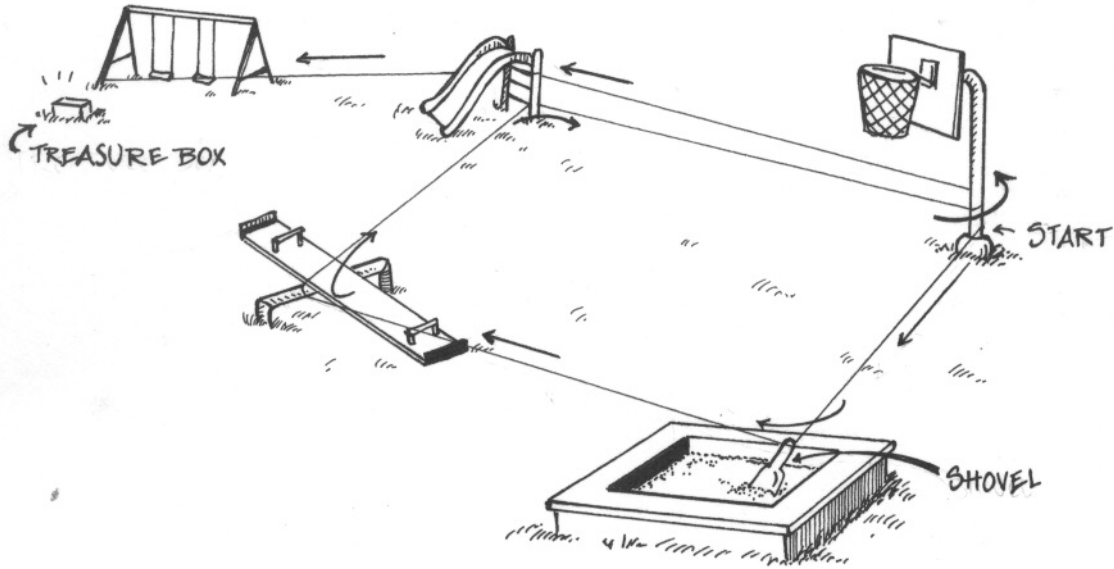

★ Susan R. Forbes, Daytona Beach, FL

## Good Luck Pet Rocks

### Materials

Rocks • paint • paintbrushes • moveable eyes, feathers, rickrack, and other decorating items • glue

### What to do

1. Take the children on a walk outdoors. Encourage them to collect rocks to bring back to the classroom.
2. Let them paint their rocks any color.
3. Encourage them to decorate their rocks by gluing on feathers, rickrack, and eyes.
4. Place them in the classroom garden for good luck.

★ Lisa Chichester, Parkersburg, WV

## Rock Garden

### Materials

---

Books on landscaping and gardens • big and small rocks • garden tools • plants

### What to do

---

1. Help the children design a garden. Bring in landscaping and gardening books for them to look at for ideas.
2. Try making an outdoor rock garden on the playground.
3. Ask the children to find rocks by their homes and bring them in. Buy some plants from your local garden store, or ask parents to donate them.
4. On a nice day, bring in gardening tools and let the children plant and set up the garden.
5. Look for big rocks on the playground or in the ground while digging up your flowerbed.
6. If you wish to keep your rock garden year after year, try planting plants that will come back each year.

★ Cookie Zingarelli, Columbus, OH

## Shadow Chasers

### Materials

---

Sunny day • sidewalk or cement play area • sidewalk chalk

### What to do

---

1. This is a great activity to do outside on a sunny day. Discuss shadows and how they are made.
2. Let the children experiment with their shadows.
3. Challenge them to make their shadows tall, short, fat, thin, or into a letter or number. They can even combine their shadows with another child to do the same commands.
4. Ask the children to work in pairs to trace around each other's shadows, and then they can color them with sidewalk chalk.